



Driver Version:	1.20
Document Revision:	3

FieldServer Driver - FieldBus FS-8700-21 LonWorks®

Now supporting SNVT Master List Version 11

Description

The LonWorks driver allows the FieldServer to transfer data to and from devices using LonWorks protocol. The FS-B30 Series and FS-B4011 can handle up to 4096 Network Variables and the FS-B2011 up to 1000 which can be of the Standard Network Variable Types (SNVT) and/or User-defined Network Variable Types (UNVT). The FieldServer LonWorks device can be used with explicit and/or implicit addressing and can be bound to a maximum of 15 other LonWorks nodes. The FS-B30 Series and FS-B4011 can handle a maximum of 4096 explicitly addressed nodes and the FS-B2011 up to 1000. The FieldServer currently supports a default of 63 network variable aliases to avoid network variable connection constraints.

The FieldServer can transfer data (Network Variables) in two ways.

- It can poll (request data from) other devices at a regular interval.
- It can send Network Variable Updates
 - At a regular interval
 - When the data has changed
 - In throttled mode using minimum and maximum send time and change on delta parameters.

The FieldServer is capable of being configured by Network Management Tools such as LonMaker. For binding (implicit mode), a Network Management Tool is necessary to create the bindings. It is possible to place a FieldServer into a Network for explicit communications without using a Network Management Tool, but this requires intimate knowledge of the network in question.

The external interface file (.XIF) for the FieldServer can be uploaded from the FieldServer for the particular application. The FieldServer differs from most other LonWorks devices in that its XIF file is not fixed due to varying applications. The list of points available to the network will vary depending on the other networks connected to the FieldServer, and the requirements of the particular application. The recommended procedure for obtaining the XIF file for the FieldServer is to upload it.

The FieldServer provides the capability of defining multiple functional blocks, but only a single LonMark object. The user can create multiple functional blocks or a LonMark object by filling



out the Node Self-Documentation String and the respective Network Variable Self-documentation String fields in the FieldServer configuration file.

The following table summarizes the FieldServer LonWorks driver's capabilities:

	FS-B2011	FS-B30	FS-B4011
Number of Network Variables ¹	1000	4096	4096
Address Table Entries	15	15	15
Network Variable Aliases	63	63	63
Number of Domain Tables ²	2	2	2
Support for SNVTs ³	Yes	Yes	Yes
Support for UNVTs	Yes	Yes	Yes
Explicit Addressing	Yes	Yes	Yes
Implicit Addressing	Yes	Yes	Yes
XIF file	Yes	Yes	Yes
Supports Polled Network Variables	Yes	Yes	Yes
Supports Network Variable Updates	Yes	Yes	Yes
Supports Configuration Properties ⁴	Yes	Yes	Yes
Supports Node and Network Variable Self-documentation Strings	Yes	Yes	Yes
Support for SCPTs ⁵	Yes	Yes	Yes
Network Management Tools such as LonMaker Supported	Yes	Yes	Yes
Commissioning without Network Management Tool Supported ⁶	Yes	Yes	Yes
Service Pin Supported	Yes	Yes	Yes
LonMark Object and Functional Profiles definition ⁷	Yes	Yes	Yes

Fieldserver Mode	Nodes	Comments
Client or Server	1	The FieldServer can only represent one LonWorks device on the LonWorks Network. A LonWorks device is unique in terms of its Neuron Chip Identification Number.

Formal Driver Type

FieldBus
Client or Server

¹ The length of Network Variable names and complexity of the configuration may limit the actual number of usable Network Variables

² One of the two domains is the zero domain used by Network Management Tools

³ SNVT Master List Version 11 is supported

⁴ Implemented with Configuration Network Variables

⁵ Only selected SCPTs are supported, extra SCPTs can be added on a per configuration basis

⁶ Explicit Addressing Only

⁷ Only approved LonMark objects are supported, see www.lonmark.org



Compatibility Matrix

FieldServer Model	Compatible with this driver
FS-B2010	No
FS-B2011	Yes
FS-B30	Yes
FS-B40	Yes

Connection Information

Connection type: FTT-10 Free Topology Network Transceiver
Baud Rates: 78125 bps (bits per second)
Hardware interface: PCC10 LonWorks adapter ISA card (FS-X40)
Built in LonWorks FTT-10 interface (FS-X2011)

Devices tested

Device	Tested (FACTORY, SITE)
LonMaker for Windows V3.1	Factory/Site
TAC Xenta	Factory/Site
TAC VISTA	Site
Electronic Systems USA	Factory
Echelon I Lon 100	Site
Plexus Technologies	Site
Invensys I/A Series	Factory
Circon UHC 300 (and others)	Factory
Distech	Site
PureChoice Nose	Factory/Site
Honeywell	Factory/Site
...and many others	



Connection configurations

The connection diagram below shows how the FieldServer FS-X20, FS-X30 and FS-X40 are connected to a LonWorks network:

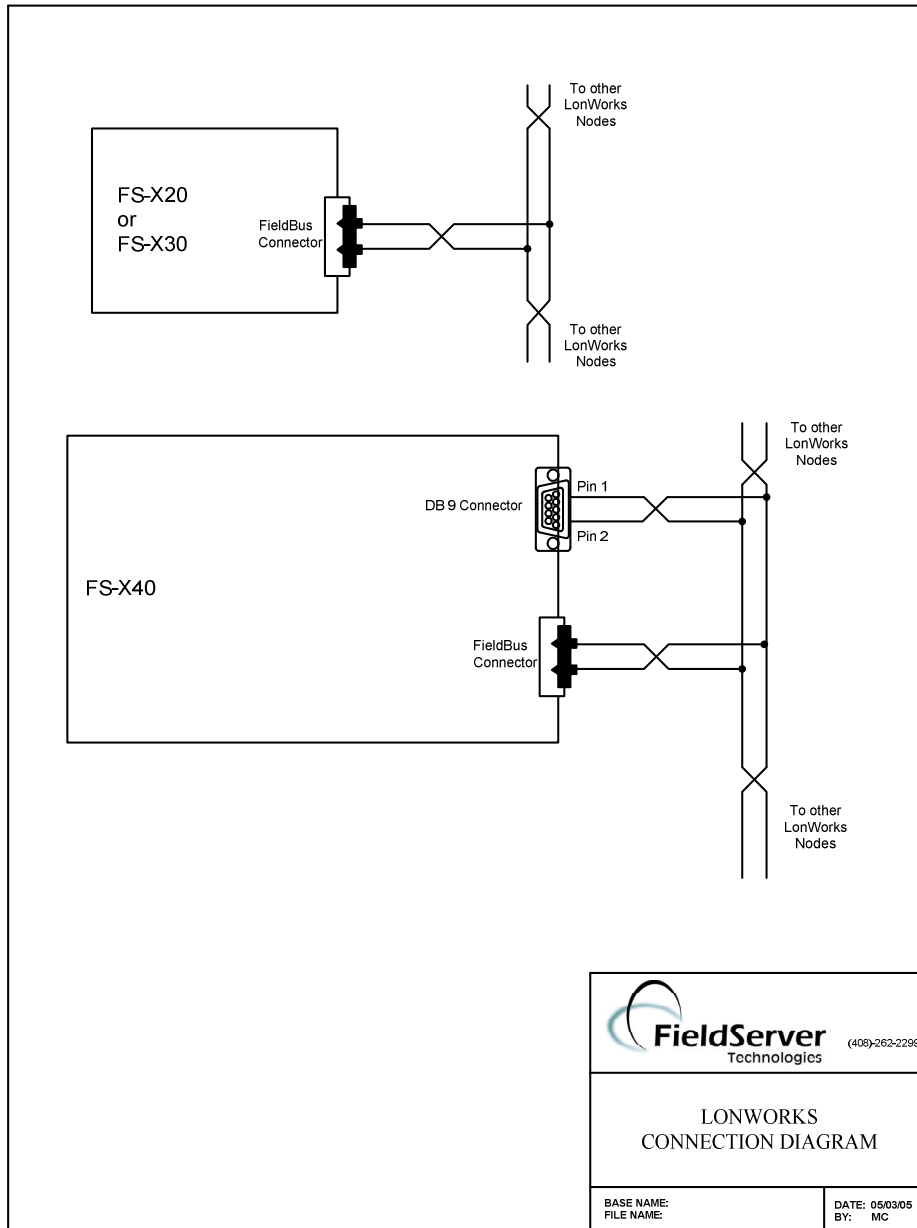

Connection Notes

The 2-wire twisted-pair connection to the network is polarity insensitive. The FTT-10 network is a free topology network which supports star, loop and / or bus wiring connections. Please refer



to the FTT-10A Free Topology Transceiver User's Guide from Echelon Corporation for recommended wiring practices if necessary.

Communications functions - Supported functions at a glance:

Data Types Supported

FieldServer Data Type	Description (or Device Data Type)
Integers (Long, short, signed, unsigned)	SNVTs and UNVTs can be presented, stored and moved into any FieldServer data type
Float	
Byte	
Bit	

List of SNVT's supported: - The "reserved" entries are for LonMark.

SNVT number	SNVT Name
0	UNVT
1	SNVT_amp
2	SNVT_amp_mil
3	SNVT_angle
4	SNVT_angle_vel
5	SNVT_btu_kilo
6	SNVT_btu_mega
7	SNVT_char_ascii
8	SNVT_count
9	SNVT_count_inc
10	SNVT_date_cal
11	SNVT_date_day
12	SNVT_date_time
13	SNVT_elec_kwh
14	SNVT_elec_whr
15	SNVT_flow
16	SNVT_flow_mil
17	SNVT_length
18	SNVT_length_kilo
19	SNVT_length_micr
20	SNVT_length_mil
21	SNVT_lev_cont
22	SNVT_lev_disc
23	SNVT_mass
24	SNVT_mass_kilo
25	SNVT_mass_mega
26	SNVT_mass_mil
27	SNVT_power
28	SNVT_power_kilo
29	SNVT_ppm
30	SNVT_press

SNVT number	SNVT Name
31	SNVT_res
32	SNVT_res_kilo
33	SNVT_sound_db
34	SNVT_speed
35	SNVT_speed_mil
36	SNVT_str_asc
37	SNVT_str_int
38	SNVT_telcom
39	SNVT_temp
40	Reserved Entry
41	SNVT_vol
42	SNVT_vol_kilo
43	SNVT_vol_mil
44	SNVT_volt
45	SNVT_volt_dbmv
46	SNVT_volt_kilo
47	SNVT_volt_mil
48	SNVT_amp_f
49	SNVT_angle_f
50	SNVT_angle_vel_f
51	SNVT_count_f
52	SNVT_count_inc_f
53	SNVT_flow_f
54	SNVT_length_f
55	SNVT_lev_cont_f
56	SNVT_mass_f
57	SNVT_power_f
58	SNVT_ppm_f
59	SNVT_press_f
60	SNVT_res_f
61	SNVT_sound_db_f



Protocol Driver



A Sierra Monitor Company

SNVT number	SNVT Name
62	SNVT_speed_f
63	SNVT_temp_f
64	SNVT_time_f
65	SNVT_vol_f
66	SNVT_volt_f
67	SNVT_btu_f
68	SNVT_elec_whr_f
69	SNVT_config_src
70	SNVT_color
71	SNVT_grammage
72	SNVT_grammage_f
73	SNVT_file_req
74	SNVT_file_status
75	SNVT_freq_f
76	SNVT_freq_hz
77	SNVT_freq_kilohz
78	SNVT_freq_milhz
79	SNVT_lux
80	Reserved Entry
81	SNVT_lev_percent
82	SNVT_multiplier
83	SNVT_state
84	SNVT_time_stamp
85	SNVT_zerospans
86	SNVT_magcard
87	SNVT_elapsed_tm
88	SNVT_alarm
89	SNVT_currency
90	SNVT_file_pos
91	SNVT_muldiv
92	SNVT_obj_request
93	SNVT_obj_status
94	SNVT_preset
95	SNVT_switch
96	SNVT_trans_table
97	SNVT_override
98	SNVT_pwr_fact
99	SNVT_pwr_fact_f
100	SNVT_density
101	SNVT_density_f
102	SNVT_rpm
103	SNVT_hvac_emerg
104	SNVT_angle_deg
105	SNVT_temp_p
106	SNVT_temp_setpt

SNVT number	SNVT Name
107	SNVT_time_sec
108	SNVT_hvac_mode
109	SNVT_occupancy
110	SNVT_area
111	SNVT_hvac_overid
112	SNVT_hvac_status
113	SNVT_press_p
114	SNVT_address
115	SNVT_scene
116	SNVT_scene_cfg
117	SNVT_setting
118	SNVT_evap_state
119	SNVT_therm_mode
120	SNVT_defr_mode
121	SNVT_defr_term
122	SNVT_defr_state
123	SNVT_time_min
124	SNVT_time_hour
125	SNVT_ph
126	SNVT_ph_f
127	SNVT_chlr_status
128	SNVT_tod_event
129	SNVT_smo_obscur
130	SNVT_fire_test
131	SNVT_temp_ror
132	SNVT_fire_init
133	SNVT_fire_indctc
134	SNVT_time_zone
135	SNVT_earth_pos
136	SNVT_reg_val
137	SNVT_reg_val_ts
138	SNVT_volt_ac
139	SNVT_amp_ac
140	Reserved Entry
141	Reserved Entry
142	Reserved Entry
143	SNVT_turbidity
144	SNVT_turbidity_f
145	SNVT_hvac_type
146	SNVT_elec_kwh_l
147	SNVT_temp_diff_p
148	SNVT_ctrl_req
149	SNVT_ctrl_resp
150	SNVT_ptz
151	SNVT_privacyzone

FieldServer Technologies, 1991 Tarob Court, Milpitas, CA 95035 USA

■ Tel: 408-262-2299, ■ Fax: 408-262-9042 ■ Toll-Free: 888-509-1970

Email: sales@fieldserver.com

Website: www.fieldserver.com



Protocol Driver



A Sierra Monitor Company

SNVT number	SNVT Name
152	SNVT_pos_ctrl
153	SNVT_enthalpy
154	SNVT_gfci_status
155	SNVT_motor_state
156	SNVT_pumpset_mn

SNVT number	SNVT Name
157	SNVT_ex_control
158	SNVT_pumpset_sn
159	SNVT_pump_sensor
160	SNVT_state_64
161	SNVT_nv_type

Read Operations supported

FieldServer as a Client	FieldServer as a Server
Polled Network Variables:	Polled Network Variables:
-Send Network Variable Fetch	-Respond to Network Variable Fetch
-Send Network Variable Poll	-Respond to Network Variable Poll

Write (Control) Operations supported

FieldServer as a Client	FieldServer as a Server
Network Variables Updates:	Network Variables Updates:
-Send Network Variable Updates	-Accept Network Variable Updates

Unsupported Functions and Data Types

Function	Reason
Programming messages	FieldServer is a data transfer device, and as such, programming messages are not required
Direct Memory Read / Writes under user control	The driver uses the Echelon MIP which handles direct memory read and writes



THIS PAGE INTENTIONALLY LEFT BLANK